

USER MANUAL

2 YEAR WARRANTY

CTEK DC/DC BATTERY CHARGER **D250S DUAL**
AND 12V POWER MANAGEMENT SYSTEM **SMARTPASS**
FOR ALL TYPES OF LEAD-ACID, WET, MF, AGM and GEL BATTERIES
FULLY AUTOMATIC



12V



FI NO DK SE NL IT ES FR DE EN

CONGRATULATIONS

on the purchase of your new CTEK professional battery management unit. This unit is part of a range of professional battery chargers from CTEK SWEDEN AB. It represents the latest technology in battery charging. Using the CTEK D250S DUAL and SMARTPASS products, you can maximize the performance of your 12VDC source.

SAFETY

- The unit is designed for 12V lead-acid batteries. Do not use the unit for any other batteries.
- Use safety glasses when connecting or disconnecting a battery.
- Battery acid is corrosive. Rinse immediately with water if acid comes into contact with skin or eyes. Seek medical advice.
- Make sure that the cables are not being pinched and are not in contact with warm surfaces or sharp edges.
- While charging, a battery can emit explosive gases; avoid sparks in the immediate area.
- Always provide for proper ventilation during charging.
- Avoid covering the unit.
- D250S DUAL is not reverse polarity protected.
- Disconnect battery poles before installation

All installations on boats must follow ISO 10133. Please note!

1. Connections from the battery must be fused close to the battery.
2. Batteries must be permanently mounted in ventilated areas.
3. Cables must be placed in tubes, separated from cables for 230V (shore power), or be attach to the surface every 300mm.
4. Cables in the engine room must be rated to withstand 70°C

D250S DUAL

The D250S DUAL has 2 inputs. The Service battery will be charged from the alternator, solar panel, or both in combination. The solar panel adjusts itself to the Starter battery voltage. The Starter battery will be charged and maintained directly by the solar panel if the Service battery is fully charged.

D250S DUAL

FEATURES:

- Multi-step 20A temperature compensated battery charging and battery maintenance.
- Battery separation of Starter and Service batteries.
- Maximum power point tracking for solar panels charging the Service battery.
- Two power source inputs (alternator, solar, wind, Supply battery and other).
- Coordination of the two inputs, allowing parallel operation.
- The auxiliary input will also charge and maintain the Starter battery.

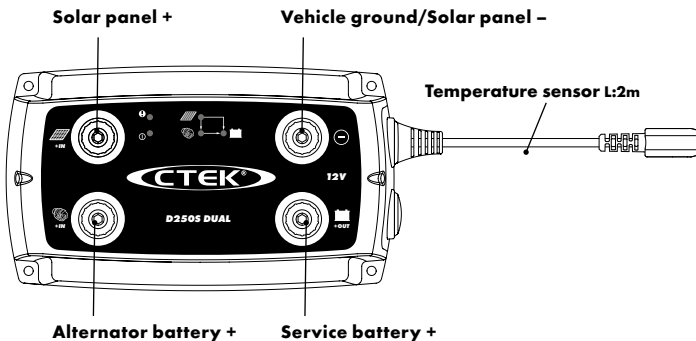

DEFINITIONS SOLAR PANEL

Depending on the application, it could also be referred to as

- PV panel
- Photovoltaic panel

CONNECTIONS

- Solar panel
- Wind power

DEFINITIONS ALTERNATOR BATTERY

Depending on the application, it could also be referred to as

- Starter battery

CONNECTIONS

- Trailer coupling
- Alternator
- SMARTPASS Alternator +

DEFINITIONS SERVICE BATTERY

Depending on the application, it could also be referred to as

- House battery
- Domestic battery
- Consumer battery

CONNECTIONS

- Electrical equipment
- Battery bank
- SMARTPASS service battery +

D250S DUAL LAMPS

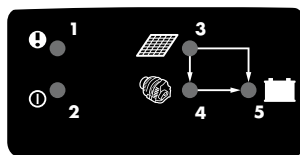

- 1. Error lamp**
- 2. Power lamp**
- 3. Solar power lamp**
- 4. Alternator battery lamp**
- 5. Service battery lamp**

D250S DUAL LAMP FUNCTION

LAMP	FUNCTION
Power lamp	D250S DUAL connected correctly, ready to use
Alternator battery lamp	Alternator running
Service battery lamp	Charging of Service battery
Solar panel lamp	Solar panel in operation

D250S DUAL LAMP INDICATION DURING NORMAL OPERATION

LIT WITH A STEADY GLOW				
●	●	●		Service battery charged by the alternator
●		●	●	Service battery charged by the solar panel
●	●	●	●	Service battery charged by both the alternator and solar panel
●	●		●	Service battery fully charged. Alternator battery maintained by the solar panel

D250S DUAL LAMP ERROR INDICATION

					EXPLANATION	RECOMMENDATION
●					High temperature detected at either unit or service battery	Consider relocating unit and/or service battery
●	●		●		Service battery connection problem detected	Check Service battery connection and fuse
●			●		Service battery connection problem detected	Check Service battery connection and fuse
●	●				Service battery connection problem detected	Check Service battery connection and fuse

● Steady lamp

Flashing lamp

SMARTPASS

SMARTPASS can operate as a stand-alone unit, but works best in combination with D250S DUAL. The SMARTPASS creates a priority path for charging the Service battery to recharge it more quickly and efficiently. Attached energy sources like solar, wind or shore power will charge both the Service and the Starter batteries through the SMARTPASS. Service batteries that are overheated due to age, high ambient temperature or other battery problems will be protected from high alternator current.

SMARTPASS

FEATURES:

The CTEK SMARTPASS adds additional functionality for higher output alternators, larger battery banks and/or high parallel loads.

- Separation of consumers and Service batteries during charging, which improves the charging capacity significantly, and lowers the consumer voltage, which increases expected service life of lights and other electronics.
- Service battery watch, which avoids harmful deep discharges that otherwise would shorten battery life. The battery watch also protects navigation, radio and emergency light from being out of electricity.
- Over-temperature protection of Service battery. High battery temperature could significantly reduce battery life.
- Maintenance charge of Starter battery, which simplifies installation with fewer components.
- Simplified installation of AC/DC chargers (shore power). Only one output from the AC/DC charger needed.

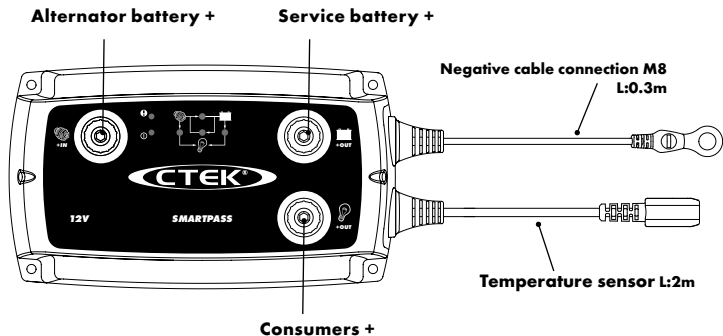

DEFINITIONS ALTERNATOR BATTERY

Depending on the application, it could also be referred to as

- Starter battery

CONNECTIONS

- Trailer coupling
- Solar panel
- Wind power
- Alternator
- D250S DUAL Alternator battery +

DEFINITIONS SERVICE BATTERY

Depending on the application, it could also be referred to as

- House battery
- Domestic battery
- Consumer battery

CONNECTIONS

- Electrical equipment
- Battery bank
- D250S DUAL Service battery +

DEFINITIONS CONSUMERS

Depending on the application, it could also be referred to as

- Electrical equipment +

CONNECTIONS

- Electrical equipment

SMARTPASS LAMPS

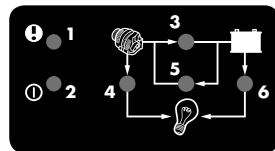

1. Error lamp
2. Power lamp
3. Service battery charging lamp
4. Alternator battery consumption lamp
5. Alternator battery charging lamp
6. Service battery consumption lamp

The CTEK SMARTPASS is designed to work together with 1-2 CTEK D250S DUAL, but can also be used alone.

SMARTPASS LAMP FUNCTION

LAMP		STEADY	FLASHING
①	Power lamp	Unit ready to use	
2	Alternator battery consumption lamp	Engine running	Too high current through relay
1	Service battery charging lamp	Charging Service battery	
4	Service battery consumption lamp	Consumers powered by Service battery	Too high current through relay
3	Alternator battery charging lamp	Alternator battery maintained by Service battery	Too high current through relay

SMARTPASS LAMP INDICATION DURING NORMAL OPERATION

①	2	1	4	→	3	EXPLANATION
●	●	●	●			High current from alternator to service battery. Consumer powered by alternator
●	●	●				Reduced current from alternator to service battery. Consumer powered by alternator
●	●					Consumer powered by alternator. Battery charged by D250S DUAL charger
●					●	Pulse maintenance of starter battery

SMARTPASS LAMP ERROR INDICATION

● Steady lamp ☀ Flashing lamp

①	2	1	4	3	!	EXPLANATION	RECOMMENDATION
		☀	☀	☀	●	Service battery overheated	Check condition and/or installation
		☀			●	Too high current through or temperature at internal relay. Too high Service battery charge current.	Check service battery. Reduce alternator size or add one more D250S DUAL in parallel. Service battery bank too deeply discharged.
	☀				●	Too high current through or temperature at internal relay. Too many consumers connected at the same time.	Consider relocation of unit. Reduce power usage.
				☀	●	Too high current through or temperature at internal relay. Too high current to starter battery.	Starter battery problems, check battery.
			☀		●	Too high current through or temperature at internal relay. Too many consumers connected.	Relocate unit or reduce concurrent use of consumers.
			☀		●	Battery watch activated. Service battery too low	Recharge Service battery

INSTALLATION OF UNIT

1. Attach the temperature sensor holder on a flat surface on one Service battery. Position it as close as possible to a positive post.
2. Use the included drill template. Wiring is simplified if the units are installed according to the drill template, but other setups are possible.
3. Install the unit(s) on a surface where it can be properly fixed and where the unit is not exposed to fuels, oils or splashes of dirt.
4. Mount the unit with screws intended for the surface and attach it with one screw in each of the four holes in the corners of the unit. See picture 1. Mount the unit with M4 or ST4.2 screws. The required torque depends on the surface for mounting. Fig. 1 shows a CTEK D250S. The same procedure is used for all devices.
5. Attach the cables and mount the cable screws with a torque of 7 Nm. Use tool - hand power without tools is not enough.

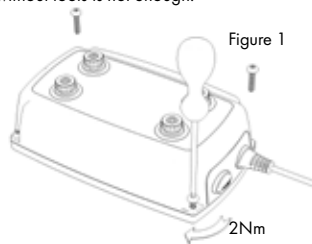

Figure 1

INSTALLATION OF CABLES

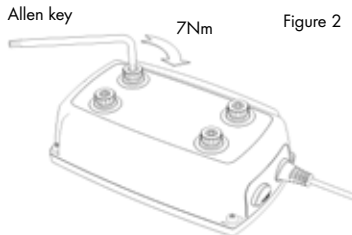
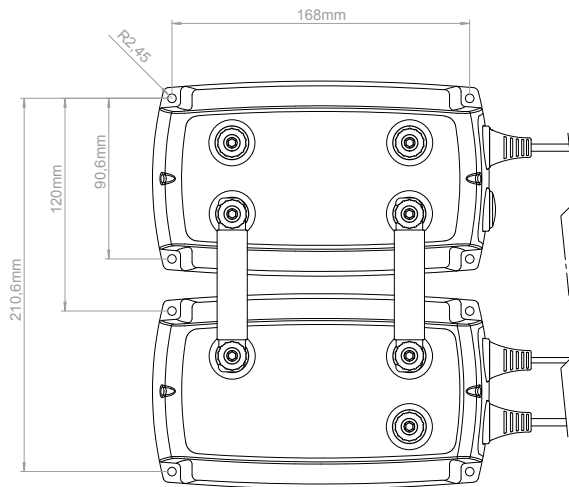

Figure 2

DRILL TEMPLATE



SOLAR PANEL

SITUATION

Solar panel

PROBLEM

A solar panel with 36 cells produces maximum power at about 17V. Many regulators reduce the voltage by "burning off" energy.

SOLUTION

The D250S DUAL searches for the Maximum Power Point and charges the battery perfectly with very high efficiency.

TIP 1

Mount the temperature sensor on the Service battery.

Boat: All installation should be done in accordance with ISO10133



WARNING!

- Max 22V input
- Do not connect two solar panels in series

INSTALLATION SHEET 1

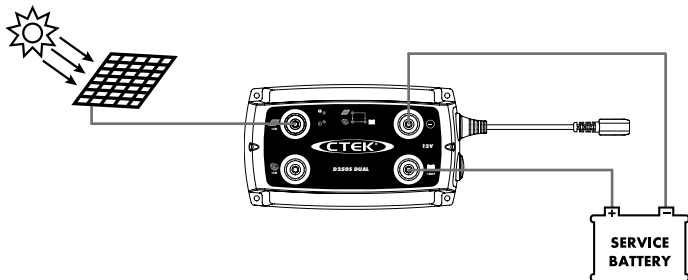

SMALL SERVICE BATTERY

SITUATION

One alternator feeding a Starter battery and a small Service battery

PROBLEM

The Service battery will take a very long time to recharge due to low alternator voltage. Due to this, the battery will underperform and die prematurely.

SOLUTION

The D250S DUAL charges the Service battery quickly and very efficiently. The battery will be fully charged, produce more and last significantly longer

TIP 2

Refer to Tip 1.

Alternators with voltage sensor cables should connect this on the Starter battery

3. Caravan/trailer: For 13-pole contact, connect D250S DUAL alternator battery + to pin #9. Connect pin #13 to D250S DUAL vehicle ground -.

WARNING!

- Max 22V input

INSTALLATION SHEET 2

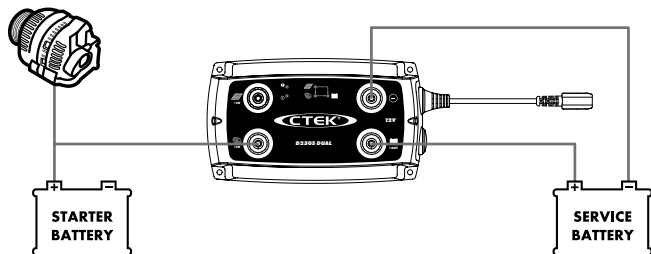

LARGE BATTERY BANK

SITUATION

One alternator feeding a Starter battery and a large Service battery bank.

PROBLEM

The Starter battery will not be fully charged and might not always be able to start the engine.

SOLUTION

The D250S DUAL recharges the Starter battery quickly to 100%, which guarantees trouble-free engine starts. The Starter battery will be pulse maintained directly from the Solar panel.

TIP 3

Mount the temperature sensor on the Starter battery.

WARNING!
- Max 22V input

INSTALLATION SHEET 3

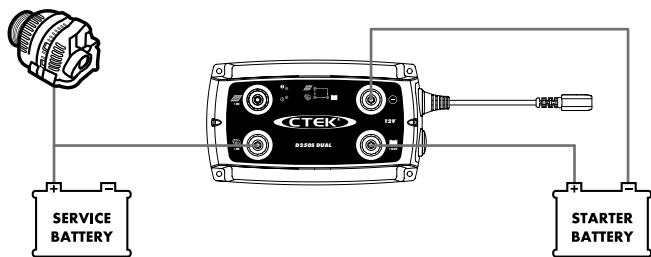

SOLAR PANEL

SITUATION

One alternator and a Solar panel feeding a Starter battery and a small Service battery.

PROBLEM

The Service battery will take a very long time to recharge due to low alternator voltage. The Solar panel is difficult to synchronize with the alternator. Due to these issues, the battery will underperform and die prematurely.

SOLUTION

The D250S DUAL charges the Service battery quickly and very efficiently from both the Alternator and the Solar panel. The Solar panel produces at its maximum power point when the engine is off. When both the Solar panel and the Alternator are on, the Solar panel adjusts to the Alternator. The battery will be fully charged, produce more and last significantly longer.

TIP 4

See Tip 1 and Tip 2.



WARNING!

- Max 22V input
- Do not connect two solar panels in series

INSTALLATION SHEET 4

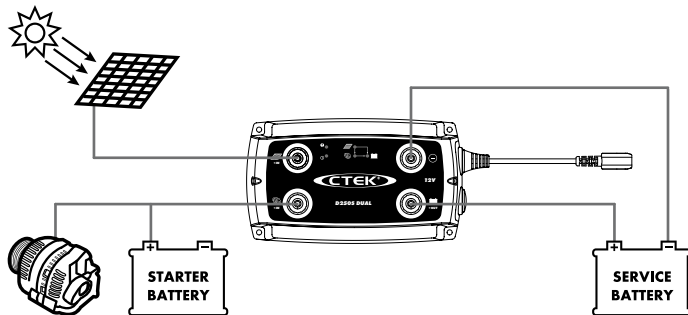

LARGE SERVICE BATTERY

SITUATION

One alternator feeding a Starter battery and a large Service battery

PROBLEM

The Service battery will take a very long time to recharge due to low alternator voltage and restrictions in how the alternator current is used. The Solar panel is difficult to synchronize with the alternator. Due to these issues, the battery will underperform and die prematurely.

SOLUTION

The SMARTPASS separates the two battery banks when the engine is off. With the engine on, the alternator charges the service battery with its maximum current until it has tapered off to the D250S DUAL max level. Then the D250S DUAL charger finalizes the charge. The recharge time is minimized. Solar panels are easily integrated and synchronized if a D250S DUAL is used together with the SMARTPASS.

TIP 5

See Tip 1, Tip 2 and Tip 4

Wires that are connected to both SMARTPASS and D250S DUAL should be connected to SMARTPASS.



WARNING!

- Max 22V input
- Do not connect two solar panels in series

CONNECTING AC/DC CHARGERS

SITUATION

230/110V charger for the Service and Starter battery

PROBLEM

The 230/110V charger should charge both the Service and the Starter battery, and be synchronized with all other energy sources.

SOLUTION

The single output 230/110V charger is connected directly to the Service battery. The Starter battery is pulse charged through the SMARTPASS, going backwards. The solar panel will also charge the Starter battery backwards through the SMARTPASS

TIP 6

See Tip 1, Tip 2, Tip 4 and Tip 5

The battery cables of the 230/110V charger are connected directly to the Service battery.



WARNING!

- Max 22V input
- Do not connect two solar panels in series

INSTALLATION SHEET 5

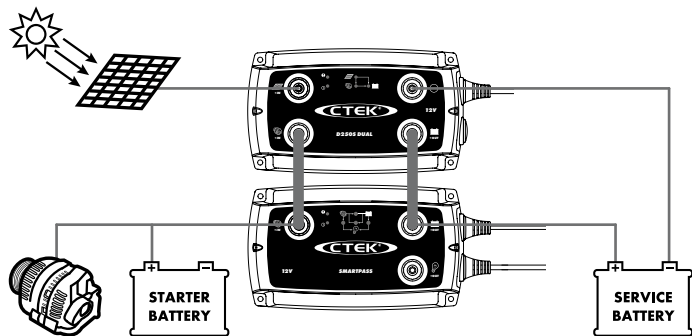

INSTALLATION SHEET 6

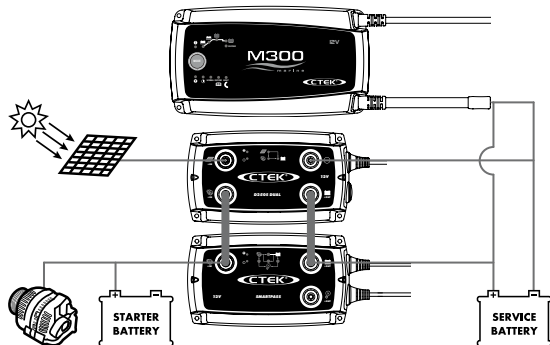

CONNECTING CONSUMERS

SITUATION

Connection of consumers to the system

PROBLEM

Many batteries die prematurely if they are discharged too much. Too little power might be delivered to critical consumers, like navigation, radio and emergency lights

SOLUTION

Critical consumers are connected directly to the battery. Others, such as refrigerator, main light and heating are connected to the SMARTPASS. When the Service battery is down to a critical level, then the SMARTPASS disconnects these noncritical consumers.

TIP 7

See *Tip 1, Tip 2, Tip 4, Tip 5 and Tip 6.*

High current consumers (>80A) should be connected directly to the Service or Starter battery



INSTALLATION SHEET 7

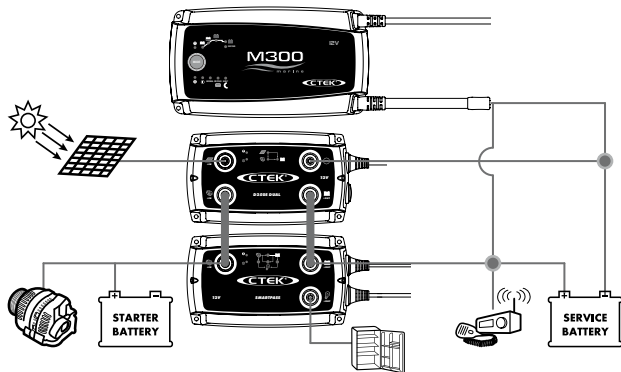

CHARGING PROGRAM D250S DUAL

The charger starts charging the target battery when the supply voltage exceeds 13.1V for 5 sec (engine on).
The charger stops charging the target battery when the supply voltage drops below 12.8V for 10 sec (engine off).

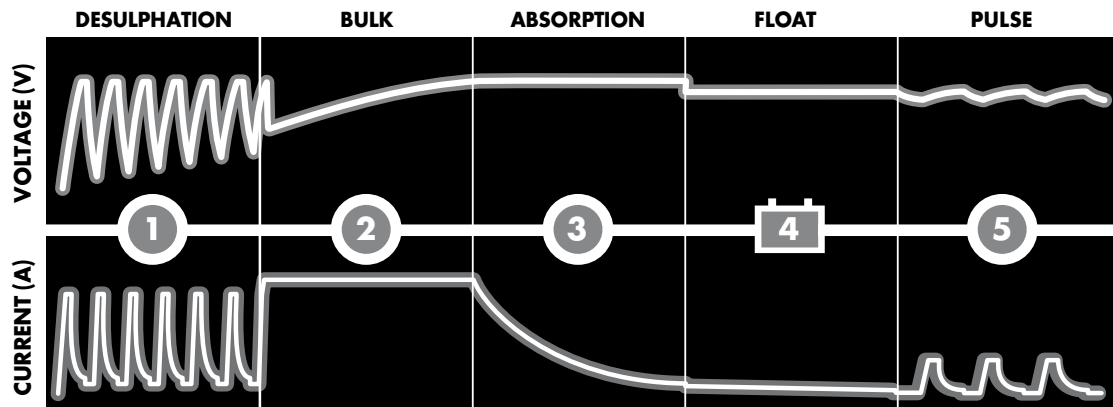

*Supply program is not time or voltage limited.

STEP 1 DESULPHATION

Detects sulphated batteries. Pulsing current and voltage, removes sulphate from the lead plates of the battery restoring battery capacity.

STEP 2 BULK

Charging with maximum current until approximately 80% battery capacity.

STEP 3 ABSORPTION

Charging with declining current to maximize up to 100% battery capacity.

STEP 4 FLOAT





Maintaining the battery voltage at maximum level by providing a constant voltage charge.

STEP 5 PULSE

Maintaining the battery at 95-100% capacity. The charger monitors the battery voltage and gives a pulse when necessary to keep the battery fully charged.

CABLE DIMENSIONS

Recommended minimum cable dimensions in mm²

MIN CABLE DIMENSIONS						
UNIT	CABLE	0.5m	1m	2m	5m	10m
D250S/D250S DUAL	+IN 	4mm ²	4mm ²	4mm ²	6mm ²	10mm ²
	+OUT 	4mm ²	6mm ²	10mm ²		
SMARTPASS	Lead to ground 	1.5mm ²	1.5mm ²	1.5mm ²	1.5mm ²	1.5mm ²
	Connection Unit*	4mm ²	6mm ²	10mm ²	10mm ²	10mm ²
SMARTPASS	+IN 	10mm ²	16mm ²	16mm ²	25mm ²	25mm ²
	+OUT 	10mm ²	16mm ²	16mm ²		

*Use included connectors if possible. The cable dimensions are if the units are mounted at different locations.

TECHNICAL SPECIFICATIONS

Charger model	D250S DUAL	SMARTPASS
Model number	1027	1058
Max input voltage	22V	22V
Charging voltage	14.4V at 25°C, temperature compensated	-
Charging current	20A	80A
Back current drain	<1Ah/month	<1Ah/month
Ripple*	<4%	
Ambient temperature	-20°C to +50°C, output power is reduced automatically at high temperatures	
Charger type	5-step fully automatic charging	
Battery types	All types of 12V lead-acid batteries (WET, MF, Ca/Ca, AGM and GEL)	
Battery capacity	40-300Ah	75-800Ah
Dimensions	197 x 93 x 49mm (L x W x H)	
Insulation class	IP65 (splash and dust proof)	
Weight	0.73kg	0.74kg
MPPT**	Yes	-

**) The quality of the charging voltage and charging current are very important. High current ripple heats the battery and ages the positive electrode. High voltage ripple can damage other equipment connected to batteries. The battery chargers from CTEK produce very high-quality voltage and current with low ripple*

***) MPPT (Maximum Power Point Tracking) finds the best combination of supply current and voltage to maximize the power output. This is especially important for Photovoltaic (Solar) Panels and trailer campers with wiring constraints.*

TEMPERATURE PROTECTION

T

SMARTPASS has a temperature sensor cable. The units will automatically protect the service battery if the temperature and charging voltage together are too high. Charging will then only be performed by the D250S battery charger. The temperature should be measured close to the battery, therefore attach the sensor to the battery.

LIMITED WARRANTY

CTEK SWEDEN AB, issues this limited warranty to the original purchaser of this product. This limited warranty is not transferable. The warranty applies to manufacturing faults and material defects for 2 years from the date of purchase. The customer must return the product together with the purchase receipt. This warranty is void if the battery charger has been opened, handled carelessly or repaired by anyone other than CTEK SWEDEN AB or its authorised representatives. One of the screw holes in the bottom of the charger is sealed. Removing or damaging the seal will void the warranty. CTEK SWEDEN AB makes no warranty other than this limited warranty and is not liable for any costs other than those mentioned above. For example, consequential damages are not covered. Moreover, CTEK SWEDEN AB is not obligated to any other warranty other than this warranty.

CTEK PRODUCTS ARE PROTECTED BY

2010-01-27

Patents	Designs	Trade marks
EP1618643	RCD 000509617	CTM TMA669987
SE525604	US D571179	CTM 844303
US7541778B2	US D575225	CTM 372715
EP1744432 pending	US D581356	CTM 3151800
EP1483817 pending	US D580853	CTM 405811
SE524203	RCD 321216	CTM 1461716 pending
US7005832B2	RCD 200830199948X pending	
EP1716626 pending	RCD 000911839	
SE526631	RCD 081418	
US-2006-0009160-A1 pending	US D29/319135 pending	
EP1903658 pending	RCD 001119911	
EP1483818	RCD 321197	
US7629774	RCD 321198	
SE528232	RCD 200830120183.6 pending	
EP09170640.8 pending	ZL200830120184.0	
US12/564360 pending	RCD 000835541	
EP09180286.8 pending	US D596125	
US12/646405 pending	US D596126	

SUPPORT

CTEK offers professional custom support: www.ctek.com. For the latest revised user manual, see www.ctek.com. By e-mail: info@ctek.se, by telephone: +46(0) 225 351 80, by fax: +46 225 351 95. By mail: CTEK SWEDEN AB, Rostugnsvägen 3, SE-776 70 VIKMANSHYTTAN, SWEDEN.

VIKMANSHYTTAN, SWEDEN 2010-06-15

Jarl Ugglå, President
CTEK SWEDEN AB

EN

CTEK SWEDEN AB

ROSTUGNSVÄGEN 3, SE-776 70 VIKMANSHYTTAN, SWEDEN

